

REF.	PART NO.	DESCRIPTION	QTY.	REF.	PART NO.	DESCRIPTION	QTY.
1	15005	Engine, Vanguard OHV, 13 hp (FP25V)	1	23	47046	Shaft Seal	1
	15011	Engine, Honda GX390 OHV, 13 hp (FP25H)	1	24	62688	Slinger	1
	15012	Engine, Honda GX390 OHV, 13 hp (FP25HE)	1	25	83018	Lock Washer, 3/8"	4
	15044	Engine, Yanmar Diesel, 10 hp (FP25Y)	1	26	81043	Hex Nut, 3/8-16	4
	15045	Engine, Yanmar Diesel, 10 hp (FP25YE)	1	NS	09081	Decal, Safety Sign (On Engine)	1
2	20629	Drain Plug	1	NS	08971	Decal - Warning (On Engine)	1
3	A 48843 1A	Pump Body	1	29	47913	Priming Lever	1
4	47447	Bearing, Bronze (Obsolete)	1	30	15000	Muffler (FP25V)	1
	15016	Bearing, Stainless Steel	1		15008	Muffler (FP25H/HE)	1
5	PA 00125	Impeller	1		15202	Muffler (FP25Y/YE)	1
6	47468	O-Ring	1	31	82496	Screw, Hex Head, 1/4-20 x 1"	1
7	80095	Screw, 3/8-16 x 1" (FP25V/H/HE)	4	32	15048	Locking Hex Nut, 1/4-20	1
	15056	Screw, Metric, 8mm x 30mm (FP25Y/YE)	4	33	66744	Spring Pin	1
8	84010	Washer, Flat, 3/8"	4	34	47916 1	Flapper Valve	1
9	84046	Washer, Flat, 3/8"	8	35	PS 00255	Muffler Brace (FP25V/H/HE)	1
10	81225	Hex Nut, 12-24	1		15178	Muffler Brace (FP25Y/YE)	1
11	48488	Washer, Flat	1	36	54756 B	Muffler Strap (FP25V/H/HE)	1
12	48845	Flapper Valve	1		15186	Muffler Clamp (FP25Y/YE)	1
13	47361	Valve Weight	1	37	15040 1	Priming Venturi Body	1
14	80676	Screw, Hex Head, 12-24 x 5/8"	1	38	15039	Priming Venturi Nozzle	1
15	48844 1A	Valve Body	1	39	PS 32369	Street Fitting, 1/4"	1
16	83116	Collar Washer, 3/8"	5	40	43736	Valve	1
17	82479	Socket Screw, 3/8-16 x 2"	5	41	15117	Vacuum Line, Flexible	1
18	47048	Pressure Gauge	1	42	15118	Fitting	1
19	80098	Cap Screw, Hex Head, 3/8-16 x 1-3/4"	4	43	15007	Stud, 8mm (FP25H/HE)	2
20	80446	Cap Screw, Hex Head, 1/2-13 x 1"	4	44	84004	Washer, Flat, 1/4"	1
21	84035	Washer, Flat, 1/2"	4	45	47069	Nipple, Close, 1/4"	1
22	47364 1A	Engine Adaptor	1	NS	01521	Strainer, 2½ - 8 NPS	1

TORQUE SPECS

REF NO.	Inch Pounds	Newton Meters	Notes:
7	240-300	27.1-33.9	20-25 Lbs. Ft.
14	20-25	2.3-2.8	
17	140-160	15.8-8.1	
19	160-200	18.1-22.6	
20	350-400	39.6-45.2	29.2-33.3 Lbs.-Ft.
31	---	---	Tighten until Priming Lever (Item 29) is snug, but free to move.

Pump Wet-End Kit: **FP25WE (UT-L1627Z)**
 Includes all pump parts, no engine, no roll cage, no exhaust priming system (exhaust priming system kits available separately)

FP25V / FP25VI / FP25H / FP25HE

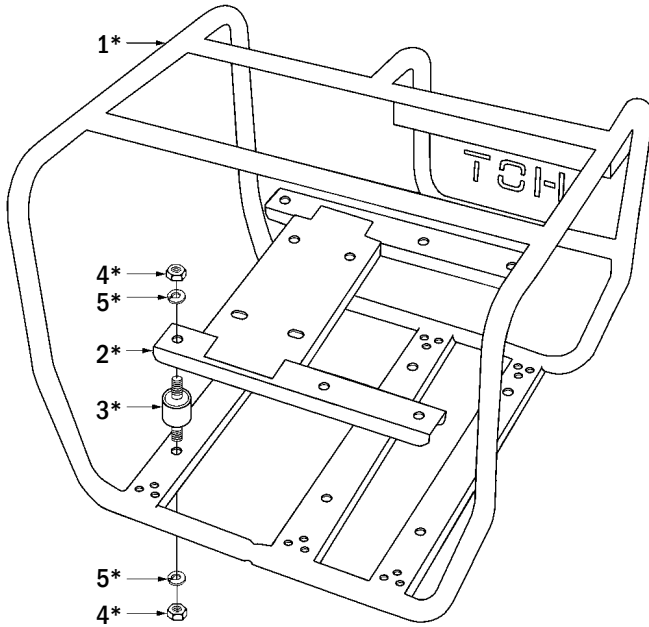

* Included in A 15025 Roll Cage Kit

REF.	PART NO.	DESCRIPTION	QTY.
*1	PA 00097	Roll Cage (FP25V/VI/H/HE)	1
*2	PA 00098	Engine Support (FP25H/HE)	1
	PA 00098	Engine Support (FP25V/VI)	1
*3	49367	Isolator	6
*4	81162	Nut, 5/16-18	12
*5	83002	Lock Washer, 5/16"	12

TORQUE SPECS

REF NO.	Inch Pounds	Newton Meters	Notes:
4	145-155	16.4-17.5	

FP25Y / FP25YE

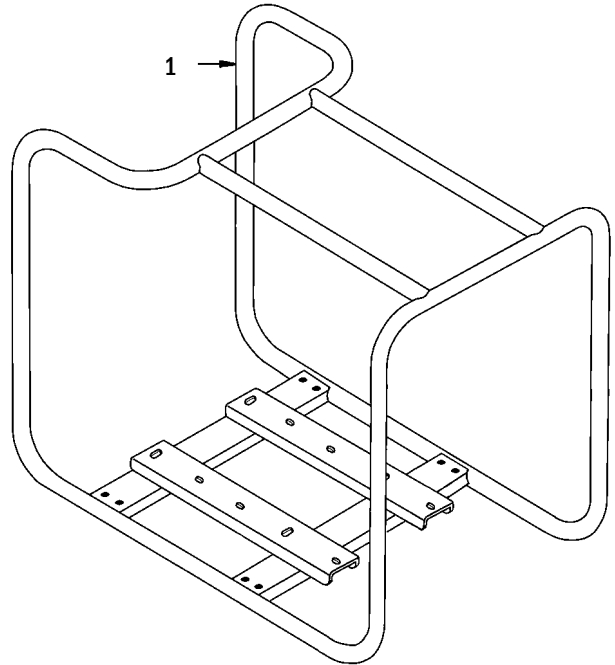

REF.	PART NO.	DESCRIPTION	QTY.
1	A 15182	Roll Cage (FP25Y/YE)	1

OTHER PARTS & ACCESSORIES:

PART NO.	DESCRIPTION
01521	Strainer, 2½ - 8 NPS
43742	Strainer, 2½ - 7½ NH
L 00247	Owner's Manual
A 15025	Roll Cage Kit (FP25H/HE/V)
01464	Nipple, 2½" NPT x 2½" BSP, Brass
01464 A	Nipple, 2½" NPT x 2½" BSP, Plated Steel
43741	Nipple, 2½" NPT x 2½" NH, Brass
15170	Adapter Bushing, 2-1/2" NPT to 2" NPT