

* Included in A 48376 B Overhaul Seal Kit

REF.	PART NO.	DESCRIPTION	QTY.
NS	15205	Engine, B&S Vanguard 5½hp (TP2B)	1
NS	00971	Engine, Honda GX160 5½hp (TP2H)	1
NS	15047	Engine, Yanmar Diesel 4.7hp (TP2Y)	1
1	54741	Impeller Nut	1
2	54740	Washer	1
3	54739 A	Impeller Bushing	1
4	54738 1	Impeller Hub (TP2B/H)	1
	54738 2	Impeller Hub (TP2Y)	1
5	50516	Crankshaft Spacer (TP2B/H)	1
	15068	Crankshaft Spacer (TP2Y)	1
6	62882 A	Shim, .010" (TP2B/H)	AR
	62883 A	Shim, .015" (TP2B/H)	AR
	15067	Shim, .010" (TP2Y)	AR
8	54132 1	Impeller	1
9	54131 2A	Impeller Housing	1
*10	62713 1A	Shaft Seal	1
11	80927	Screw, 5/16-24 x 2-1/4" (TP2B/TP2H)	4
	15066	Screw, 8mm x 2-1/4" (TP2Y)	4
12	A 49674	End Housing [includes #13 - 17]	1
13	75663 1	Nipple, 2" x 2"	1
14	54151 1	Nipple, 2" x 3-1/2"	1
15	08970	Decal - Fill Pump	1
16	08971	Decal - Warning	1
17	50912	Sleeve, End Housing	1

REF.	PART NO.	DESCRIPTION	QTY.
18	54397	Handle Pivot	4
*19	76885 A	Slinger	1
20	54660	Spring Pin	2
21	A 43971	Filler Plug [includes #22]	1
*22	18108	Gasket	1
23	A 43896	Drain Plug [includes #24]	1
*24	59910	Gasket	1
*25	54069	Gasket, Small	1
26	54136 1A	Wear Plate	1
*27	54070 A	Gasket, Large	2
*28	62874	Sealing Washer	4
29	54550 2A	Disconnect Handle	4
30	54398	Handle Stud	4
31	09081	Decal, Safety Sign (On Engine)	1
NS	54702 A	Strainer, 2"	1

Pump Wet-End Kit: **TP2WE (UT-L1615Z)**
Includes all pump parts, no engine, no roll cage, for non-metric engine

OTHER PARTS & ACCESSORIES:

PART NO.	DESCRIPTION
A 48376 B	Overhaul Seal Kit
54702 A	Strainer, Suction, 2"
15036	Foot Valve, 2"
L 19956	Owner's Manual
A 15060	Spanner Wrench Kit, 2"
A 15043	Dolly Kit
A 15022	Roll Cage Kit (TP2B/H)
15217	Shaft Seal, Viton

TORQUE SPECS

REF NO.	Inch Pounds	Newton Meters	Notes:
13	130-145	14.7-16.4	

ROLL CAGE: TP2B • TP2H • TP2Y

TORQUE SPECS

REF NO.	Inch Pounds	Newton Meters	Notes:
5	205-225	23.2-25.4	17-18.8 Lbs.-Ft.
7	205-225	23.2-25.4	17-18.8 Lbs.-Ft.
8	130-145	14.7-16.4	

* Included in A 15022 Roll Cage Kit
(Kit includes additional items for S2 models)

REF.	PART NO.	DESCRIPTION	QTY.
*1	A 08096	Roll Cage	1
*2	83002	Lock Washer, 5/16"	12
*3	84032	Flat Washer, 5/16"	16
*4	81162	Hex Nut, 5/16-18	12
*5	80087	Hex Head Cap Screw, 5/16-18 x 1-1/2"	4
*6	08101	Engine Support (TP2B/TP2H)	1
	15049	Engine Support (TP2Y)	1
*7	80083	Hex Head Screw, 5/16-18 x 3/4"	4
*8	80088	Hex Head Screw, 5/16-18 x 1-1/4"	4
*9	48789	Rubber Foot	4
*10	49733	Foot Spacer	4

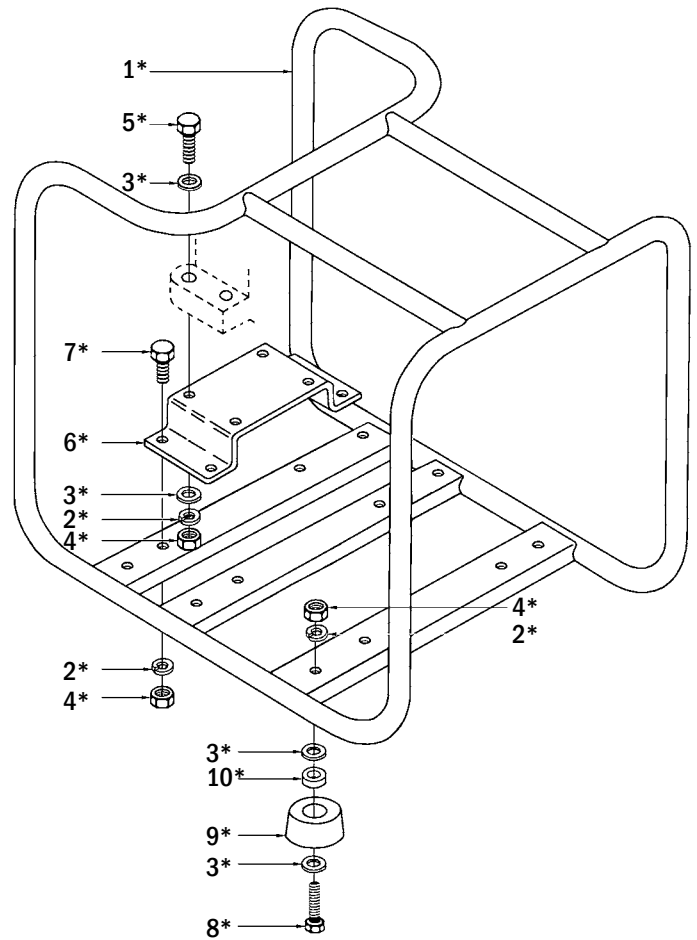

ROLL CAGE: TP2BC • TP2HC

TORQUE SPECS

REF NO.	Inch Pounds	Newton Meters	Notes:
5	205-225	23.2-25.4	17-18.8 Lbs.-Ft.
7	205-225	23.2-25.4	17-18.8 Lbs.-Ft.

REF.	PART NO.	DESCRIPTION	QTY.
1	A 15203	Roll Cage	1
2	83002	Lock Washer, 5/16"	8
3	84032	Flat Washer, 5/16"	8
4	81162	Hex Nut, 5/16-18	8
5	80087	Hex Head Cap Screw, 5/16-18 x 1-1/2"	4
6	08101	Engine Support	1
7	80083	Hex Head Screw, 5/16-18 x 3/4"	4

